

VOLVO PENTA GENSET ENGINE

TAD532GE

1500 rpm, 129 kW (175 hp) – 1800 rpm 136 kW (185 hp)

The TAD532GE is a powerful, reliable and economical Generating Set Diesel Engine.

Durability & low noise

Designed for easiest, fastest and most economical installation. Well-balanced to produce smooth and vibration-free operation with low noise level.

To maintain a controlled working temperature in cylinders and combustion chambers, the engine is equipped with piston cooling. The engine is also fitted with replaceable cylinder liners and valve seats/guides to ensure maximum durability and service life of the engine.

Low exhaust emission

The state of the art, high-tech injection and charging system with low internal losses contributes to excellent combustion and low fuel consumption.

The TAD532GE is certified for EU Stage 2 exhaust emission regulations.

Easy service & maintenance

Easily accessible service and maintenance points contribute to the ease of service of the engine.

Technical description

Engine and block

- Optimized cast iron cylinder block with optimum distribution of forces
- Piston cooling for low piston temperature and reduced ring temperature
- Drop forged steel connecting rods
- Crankshaft hardened bearing surfaces and fillets for moderate load on main and big-end bearings
- Keystone top compression rings for long service life
- Replaceable valve guides and valve seats
- Three PTO positions at flywheel end
- Lift eyelets
- Flywheel housing with connection acc. to SAE 2
- Flywheel for flexible coupling and friction clutch
- Transport brackets

Lubrication system

- Full flow disposable spin-on oil filter, for extra high filtration
- Rotary displacement oil pump driven by the crankshaft
- Deep centre oil sump, 30° inclination
- Oil filler on top
- Oil dipstick, short in front
- Integrated full flow oil cooler, side-mounted

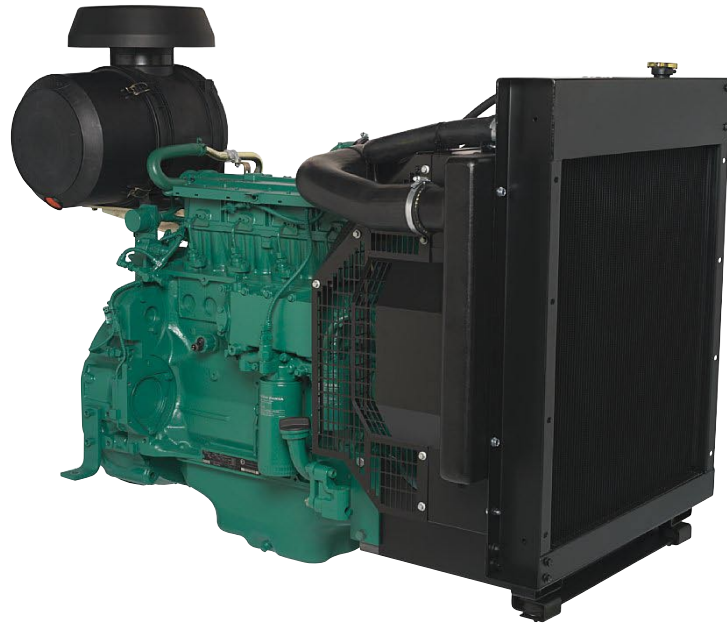

Features

- Electronic governing, EDC 4
- CAN bus communication
- Compact design
- High power to weight ratio
- Emission compliant
- Noise optimized engine design
- A wide selection of optional equipment and power settings

Fuel system

- Six hole fuel injection nozzles
- Electronic governor with smoke limiter function
- Washable fuel prefilter with water separator
- Rotary low-pressure fuel pump
- Fine fuel filter of disposable type

Intake and exhaust system

- Connection flange for exhaust line
- Turbo charger, centre low with exhaust flange
- Closed crankcase ventilation
- Heater flange in charge air inlet (without power relay)

Cooling system

- Belt driven, maintenance-free coolant pump with high degree of efficiency
- Efficient cooling with accurate coolant control through a water distribution duct in the cylinder block

- Reliable thermostat with minimum pressure drop
- Cooling water pipe, inlet and outlet
- Fan hub
- Cooling package

Electrical system

- 12 V electrical system
- Alternator 55A / 12V, low left
- Starter motor, 3.1 kW / 12V, single pole
- ECU (without high altitude sensor) control and monitoring of oil pressure, coolant temperature, coolant level, charge air pressure, engine rpm and fuel temperature compensation
- Engine wiring

TAD532GE

Technical Data

General

Engine designation.....	TAD532GE	
No. of cylinders and configuration.....	in-line 4	
Method of operation.....	4-stroke	
Bore, mm (in.).....	108 (4.25)	
Stroke, mm (in.).....	130 (5.12)	
Displacement, l (in ³).....	4.76 (290)	
Compression ratio.....	17.5:1	
Dry weight, kg (lb).....	575 (1268)	
Wet weight, kg (lb).....	606 (1336)	

Performance	1500 rpm	1800 rpm
with fan, kW (hp) at:		
Prime Power	112 (153)	115 (157)
Standby Power	125 (170)	129 (176)

Lubrication system	1500 rpm	1800 rpm
Oil consumption, liter/h (US gal/h) at:		
Prime Power	0.08 (0.021)	0.08 (0.021)
Standby Power	0.08 (0.021)	0.08 (0.021)
Oil system capacity incl filters, liter.....	13	

Fuel system	1500 rpm	1800 rpm
Specific fuel consumption at:		
Prime Power, g/kWh (lb/hph)		
25 %	239 (0.388)	261 (0.423)
50 %	213 (0.345)	224 (0.364)
75 %	210 (0.340)	218 (0.353)
100 %	214 (0.346)	222 (0.359)
Standby Power, g/kWh (lb/hph)		
25 %	228 (0.370)	243 (0.393)
50 %	210 (0.340)	218 (0.354)
75 %	209 (0.339)	218 (0.354)
100 %	216 (0.350)	225 (0.365)

Intake and exhaust system	1500 rpm	1800 rpm
Air consumption at 27°C, m ³ /min (cfm):		
Prime Power	7.55 (267)	9.0 (318)
Standby Power	8.03 (284)	9.6 (339)
Max allowable air intake restriction, kPa (In wc)	3.5 (14.1)	3.5 (14.1)
Heat rejection to exhaust, kW (BTU/min) at:		
Prime Power	90 (5118)	99 (5630)
Standby Power	104 (5914)	116 (6597)
Exhaust gas temperature after turbine, °C (°F) at:		
Prime Power	507 (945)	484 (904)
Standby Power	532 (990)	528 (983)
Max allowable back-pressure in exhaust line, kPa (In wc) at:		
Prime power	5 (20.1)	7 (28.1)
Standby Power	3 (12.0)	3 (12.0)
Exhaust gas flow, m ³ /min (cfm) at:		
Prime power	21.2 (749)	24.3 (857)
Standby Power	23.2 (818)	27.6 (973)

Cooling system	1500 rpm	1800 rpm
Heat rejection radiation from engine, kW (BTU/min)		
Prime Power	12 (683)	13 (739)
Standby Power	13 (739)	14 (797)
Heat rejection to coolant kW (BTU/min)		
Prime Power	56 (3207)	61 (3475)
Standby Power	63 (3566)	68 (3873)
Fan power consumption, kW (hp)	8 (7)	8.7 (12)

Standard equipment

Engine

Automatic belt tensioner

Lift eyelets

Flywheel

Flywheel housing with conn. acc. to SAE 2

Flywheel 10" and 11.5" disc

Vibration dampers

Engine suspension

Fixed front suspension

Lubrication system

Oil dipstick

Full-flow oil filter of spin-on type

By-pass oil filter of spin-on type

Oil cooler, side mounted

Low noise oil sump

Fuel system

Fuel filters of disposable type

Pre-filter with water separator

Intake and exhaust system

Air filter with replaceable paper insert

Air restriction indicator

Air cooled exhaust manifold

Connecting flange for exhaust pipe

Exhaust flange with v-clamp

Turbo charger, low left side

Crankcase ventilation

Cooling system

Tropical radiator incl intercooler

Gear driven coolant pump

Fan hub

Pusher fan

Fan guard

Belt guard

Control system

Engine Diesel Control 4 (EDC4) with CAN-bus

interface SAE J1939 and stand alone interface

Alternator

Alternator 55A / 12 V

Starting system

Starter motor, 3.1 kW, 12 V

Instruments and senders

Temp.- and oil pressure for automatic

stop/alarm 103°C

Engine Packing

Plastic wrapping

– optional equipment or not applicable

• included in standard specification

Dimensions TAD532GE

Not for installation

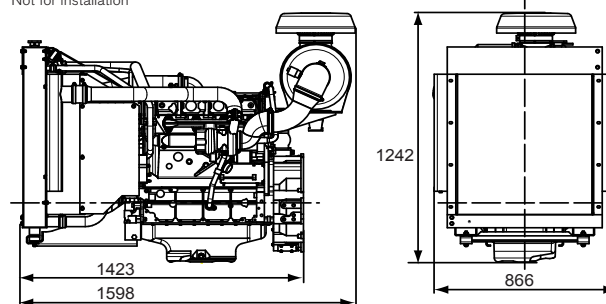

Note! Not all models, standard equipment and accessories are available in all countries.

All specifications are subject to change without notice.

The engine illustrated may not be entirely identical to production standard engines.

Power Standards

The engine performance corresponds to ISO 3046, BS 5514 and DIN 6271. The technical data applies to an engine without cooling fan and operating on a fuel with calorific value of 42.7 MJ/kg (18360 BTU/lb) and a density of 0.84 kg/liter (7.01 lb/US gal), also where this involves a deviation from the standards. Power output guaranteed within 0 to +2% at rated ambient conditions at delivery. Ratings are based on ISO 8528.

Engine speed governing in accordance with ISO 3046/IV, class A1 and ISO 8528-5 class G3

Exhaust emissions

The engine complies with Tier 2 and TA-luft exhaust emission regulations.

Rating Guidelines

PRIME POWER rating corresponds to ISO Standard Power for continuous operation. It is applicable for supplying electrical power at variable load for an unlimited number of hours instead of commercially purchased power. A10 % overload capability for governing purpose is available for this rating.

MAXIMUM STANDBY POWER rating corresponds to ISO Standard Fuel Stop Power. It is applicable for supplying standby electrical power at variable load in areas with well established electrical networks in the event of normal utility power failure. No overload capability is available for this rating. 1 hp = 1 kW x 1.36

Information

For more technical data and information, please look in the Generating Set Engines Sales Guide.

Technical data TAD532GE

General

In-line four stroke diesel engine with direct injection. Rotation direction, anti-clockwise viewed towards flywheel. Turbocharged, charge air cooled (CAC)

Number of cylinders			4
Displacement, total		litre in ³	4,76 290,7
Firing order			1-3-4-2
Bore		mm in	108 4,25
Stroke		mm in	130 5,12
Compression ratio			18:1
Dry weight	Engine and cooling package	kg	575
		lb	1268
Wet weight	Engine and cooling package	kg	606
		lb	1336

Performance		r/min	1500	1800
Standby Power	without fan	kW	129	136
		hp	175	185
	with fan low temp	kW	125	129
		hp	170	176
Prime Power	without fan	kW	116	122
		hp	158	166
	with fan low temp	kW	112	115
		hp	153	157
Torque at:	Standby Power	Nm	821	722
		lbft	606	532
	Prime Power	Nm	738	647
		lbft	545	477
Mean piston speed		m/s ft/sec	6,5 21,4	7,8 25,7
Effective mean pressure at:	Standby Power	MPa	2,2	1,9
		psi	312	281
Effective mean pressure at:	Prime Power	MPa	2,0	1,7
		psi	283	248
Total mass moment of inertia, J (mR ²)		kgm ² lbft ²	1,43 33,9	
Residual speed droop at load increase from 0 to 100%		%	≤ 5	
Friction Power		kW	6,0	8,6
		hp	8,16	11,696

Technical data TAD532GE

Engine noise emission

Test Standards: ISO 3744-1981 (E)

sound power (without fan, intake and exhaust noise)

Tolerans ± 0.75 dB(A)

		r/min	1500	1800
Measured sound power Lw	No load	dB(A)	101,3	101,9
	Standby Power	dB(A)	103,5	105,1
	Prime Power	dB(A)	103,5	105,1
Calculated sound pressure Lp at 1 m	No load	dB(A)	87,8	88,4
	Standby Power	dB(A)	90,0	91,6
	Prime Power	dB(A)	90,0	91,6

Unsilenced exhaust noise

Data calculated as sound pressure Lp.

Assumed microphone distance 1 m

	r/min	1500	1800
Standby Power	dB(A)		
Prime Power	dB(A)		

Load acceptance

Test condition: Warm engine. Load acceptance performance can vary due to actual alternator inertia, voltage regulator, type of load and local ambient conditions.

Single step load performance at 1500 rpm - EDC4

Load (%)	Speed diff %		Recovery time (s)		Remaining load (%)	Speed diff (%)		Recovery time (s)	
	Prime	Standby	Prime	Standby		Prime	Standby	Prime	Standby
0-20	2,6	3,0	0,6	0,6	20-100	17,4	23,5	3,4	6,3
0-40	5,6	6,0	1,4	1,5	40-100	9,5	11,5	2,4	3,5
0-50	6,8	7,7	1,6	1,7	50-100	8,1	9,0	2,0	2,8
0-60	8,5	9,6	1,9	2,0	60-100	6,8	7,6	1,8	2,3
0-70	10,4	13,0	2,1	2,4	70-100	5,5	6,0	1,7	2,3
0-80	13,9	18,7	2,5	3,2	80-100	3,4	4,0	1,4	1,8
0-100	26,0		4,9						
100-0	7,0	7,0	1,2	1,2					
					G3: 0-53	7,0		1,7	
					G2: 0-67	10,0		2,1	
					G3: 0-48		7,0		1,7
					G2: 0-61		10,0		2,1

Single step load performance at 1800 rpm - EDC4

Load (%)	Speed diff (%)		Recovery time (s)		Remaining load (%)	Speed diff (%)		Recovery time (s)	
	Prime	Standby	Prime	Standby		Prime	Standby	Prime	Standby
0-20	1,5	1,8	0,3	0,3	20-100	7,3	8,9	1,2	2,6
0-40	3,2	3,5	0,4	0,5	40-100	5,0	5,8	0,8	2
0-50	3,9	4,4	0,5	1,0	50-100	4,4	5,0	0,6	1,7
0-60	4,8	5,2	1,0	1,2	60-100	3,8	4,4	0,5	1,4
0-70	5,5	6,3	1,2	1,4	70-100	2,8	3,5	0,5	0,9
0-80	6,6	8,4	1,4	1,6	80-100	2,0	2,5	0,4	0,7
0-100	10,3	13,4	1,9	3					
100-0	6,0	6,0	0,8	0,8					
					G3: 0-80	7,0		1,4	
					G2: 0-96	10,0		1,7	
					G3: 0-72		7,0		1,4
					G2: 0-86		10,0		1,7

Technical data TAD532GE

Cold start performance

1500/1800

Cold start limit temperature	°C	-15
		-30*

* With manifold heater engaged, lubrication oil 15W/40

Derating, electronic governer

The engine may be operated up to 1000 m altitude and 40°C ambient air temperature without derating. For applications above 1000 m an ECU with automatic altitude derating must be used. For operations with air ambient temperature over 40°C, see below.

Altitude derating factor < 3000 m	% / m	4 / 500
Altitude derating factor > 3000 m	% / m	6 / 500
Ambient temperature derating factor	% / °C	2 / 5°C
Humidity	%	No derating

Lubrication system

		r/min	1500	1800
Lubricating oil consumption	Standby Power	liter/h	0,08	0,08
		US gal/h	0,021	0,021
Oil system capacity including filters		liter	13	
		US gal	3,4	
Oil sump capacity:	max	liter	11	
		US gal	2,9	
	min	liter	9	
		US gal	2,4	
Oil change intervals/specifications:				
Closed crankcase ventilation	ACEA: E4. API: CH-4, CI-4* full synthetic	h	500	
Open crankcase ventilation	VDS-2. ACEA: E3, E5. API: CG-4, CH-4*	h	500	
Open crankcase ventilation	VDS. ACEA: E2. API: CF, CF-4*	h	250	
Engine angularity limits:	front up	°	10	
	front down	°	10	
	side tilt	°	10	
Engine angularity limits:	front up	°	30	
	front down	°	30	
	side tilt	°	30	
Oil pressure at rated speed		kPa	450 - 480	
		psi	65 - 70	
Oil pressure shut down switch setting		kPa	200	
		psi	29	
Lubrication oil temperature:	normal	°C	110	
		°F	230	
	max	°C	125	
		°F	257	
Oil filter micron size		mm	0,040	

* See also general section in the sales guide

Technical data TAD532GE

Fuel system		r/min	1500	1800
Standby Power Specific fuel consumption at:	25%	g/kWh lb/hph	228 0,370	243 0,393
	50%	g/kWh lb/hph	210 0,340	218 0,354
	75%	g/kWh lb/hph	209 0,339	218 0,353
	100%	g/kWh lb/hph	216 0,350	225 0,365
Prime Power Specific fuel consumption at:	25%	g/kWh lb/hph	239 0,388	261 0,423
	50%	g/kWh lb/hph	213 0,345	224 0,364
	75%	g/kWh lb/hph	210 0,340	218 0,353
	100%	g/kWh lb/hph	214 0,346	222 0,359

Fuel system		r/min	1500	1800
Recommended fuel to conform to		ASTM-D975-No1 and 2-D JIS KK 2204, EN 590		
Total fuel flow		liter/h US gal/h	360 95	450 119
Feed pump pressure		kPa psi	500 - 550 73 - 80	
Feed pump max suction head		m foot	1,5 4,9	
Max allowable inlet fuel temp under operation conditions		°C °F	75 167	
Fuel filter micron size		mm	0,005	
Prefilter / Water separator		mm	0,063	
Governor type/make, standard		Heinzman / EDC4		
Injection pump type/make		PFM 1 P100 S 2005 / Bosch		

Technical data TAD532GE

Intake and exhaust system			r/min	1500	1800
Air consumption at:	Standby Power	27°C	m ³ /min	8,03	9,6
		81°F	cfm	284	339
	Prime Power	27°C	m ³ /min	7,55	9
		81°F	cfm	267	318
Air intake restriction, clean filter(s)			kPa	1	1
			in wc	4,0	4,0
Max allowable air intake restriction			kPa	3,5	3,5
			in wc	14,1	14,1
Air filter type			Single stage paper cartridge		
Air filter cleaning efficiency			%	99,85	
Heat rejection to exhaust at:	Standby Power		kW	104	116
			BTU/min	5914	6597
	Prime Power		kW	90	99
			BTU/min	5118	5630
Exhaust gas temperature after turbine at:	Standby Power	°C		532	528
		°F		990	983
	Prime Power	°C		507	484
		°F		945	904
Max allowable back pressure in exhaust line	Standby Power		kPa	3	5
			In wc	12,0	20,1
	Prime Power		kPa	5	7
			In wc	20,1	28,1
Exhaust gas flow at:	Standby Power		m ³ /min	23,2	27,6
			cfm	818	973
	Prime Power		m ³ /min	21,2	24,3
			cfm	749	857
Heat rejection to CAC	Standby Power		kW	23,7	30,7
			BTU/min	1348	1746
	Prime Power		kW	21,3	27,6
			BTU/min	1211	1570

Technical data TAD532GE

Cooling system		r/min	1500	1800
Heat rejection radiation from engine at:	Standby Power	kW	13	14
		BTU/min	762	15
	Prime Power	kW	12	13
		BTU/min	688	745
Heat rejection to coolant at:	Standby Power	kW	63	68
		BTU/min	3566	3873
	Prime Power	kW	56	61
		BTU/min	3207	3475
Recommended coolant	Volvo coolant or Volvo anticorrosion additive together with clean fresh water			
Radiator cooling system type		Closed circuit		
Radiator core area low temp cooling package		m ²	0,52	
		foot ²	5,60	
Radiator core thickness low temp cooling package		mm	60	
		in	2,36	
Radiator core thickness low temp cooling package		mm	60	
		in	2,36	
Fan diameter - low temp cooling system		mm	546	
		in	21,50	
Fan diameter - high temp cooling system		mm	596	
		in	23,46	
Fan power consumption - low temp cooling system		kW	3,8	6,6
		hp	5	9
Fan power consumption - high temp cooling system & dual speed rating		kW	5	8,7
		hp	7	12
Fan drive ratio			1,73:1	
Coolant capacity,	engine	liter	7,2	
		US gal	1,90	
	std radiator with hoses	liter	13	
		US gal	3,43	
Coolant pump		drive/ratio	1,73:1	
Coolant flow with low temp cooling system		l/s	163	205
		US gal/s	43,06	54,16
Maximum external coolant system restriction		kPa	25	35
		in wc	100	141
Thermostat,	start to open	°C	83	
		°F	181	
	fully open	°C	95	
		°F	203	
Maximum static pressure head		kPa	100	
		in wc	402	
Pressure cap setting on low temp radiator		kPa	60	
		in wc	241	
Maximum top tank temperature		°C	105	
		°F	221	
Shutdown switch setting		°C	113	
		°F	235	
Recommended draw down capacity	10% of total cooling system capacity			

Technical data TAD532GE

Cooling performance

Cooling air flow and maximum additional external restriction at different radiator air temperatures based on 105°C TTT and 50% antifreeze (radiator and cooling fan, see optional equipment)

Engine speed rpm	Air on temp °C	PRIME POWER		STANDBY POWER	
		Air flow m ³ /s	External restriction Pa	Air flow m ³ /s	External restriction Pa
1500	58	2,5	0		
	low temp				
	53	2,1	150		
	50	2,0	200		
	45	1,7	300		
	37	1,5	400		
	high temp				
	62	2,9	0		
	58	2,5	150		
	57	2,4	200		
	53	2,1	300		
	46	1,8	400		
	low temp				
	55			2,5	0
	49			2,1	150
46			2,0	200	
40			1,7	300	
32			1,5	400	
high temp					
59			2,9	0	
55			2,5	150	
53			2,4	200	
49			2,1	300	
42			1,8	400	
1800	60	3,1	0		
	low temp				
	57	2,8	150		
	55	2,6	200		
	53	2,4	300		
	49	2,2	400		
	high temp				
	64	3,6	0		
	61	3,3	150		
	60	3,1	200		
	58	2,9	300		
	56	2,7	400		
	low temp				
	57			3,1	0
	53			2,8	150
52			2,6	200	
48			2,4	300	
45			2,2	400	
high temp					
60			3,6	0	
58			3,3	150	
57			3,1	200	
55			2,9	300	
52			2,7	400	

2008-01-18

Technical data TAD532GE

Electrical system		r/min	1500	1800
Voltage and type		12V / 1 pole system		
Alternator:	make/output	Amp	Iskra/55	
	tacho output	Hz/alt. Rev	6	
	drive ratio		3,01:1	
Starter motor	make	Bosch		
	type	EV		
	kW	3,1		
Starter motor solenoid,	pull current	Amp	60	
	hold current	Amp	12	
Number of teeth on:	flywheel		129	
	cam wheel		96	
	starter motor		9	
Inrush current at +20°C		Amp	1110	
Cranking current at +20°C		Amp	370	
Crank engine speed at 20°C		rpm	160	
Starter motor battery capacity:	max	Ah	176	
	min at +5°C	Ah	110	
Stop solenoid,	max	Amp	3	
Inlet manifold heater (at 12V/24V)		kW	2 / 3,6	
Power relay for the manifold heater (at 12V/24V)		Amp	150 / 120	